

mod. CAB1400BT3P | cod. 06220030

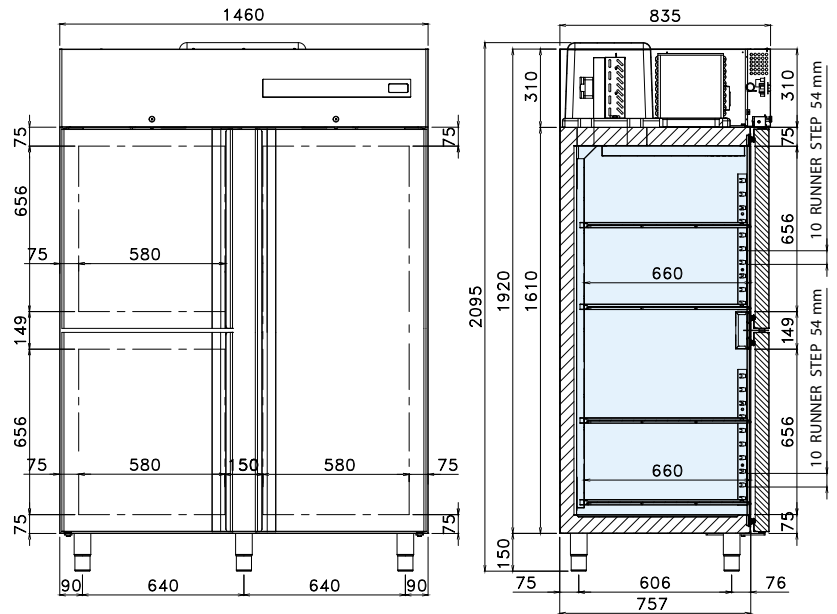

EN TECHNICAL SPECIFICATIONS

Available temperature (°C)	Dimensions W x D x H (mm)	Packaging dimensions W x D x H (mm)	Refrigerant gas	Net volum (L)	Climate class	Energy class	Power consumption (W)	Supply voltage	Annual consumption (kWh/year)
-18 / -22	1460x835x2095	1500x900x2300	R290	930	5	E	700	220-240 V 50 Hz	4657

EN TECHNICAL AND FUNCTIONAL FEATURES

- Refrigerated cabinet equipped with a monobloc unit that is tropicalized and easily removable from the body, with forced ventilated refrigeration with R290 gas
- Structure entirely in steel. Interior, walls and door in AISI 304 stainless steel
- Tested with external working environment temperatures up to 43 °C, efficiency equivalent to energy class 5
- 75 mm insulation of high pressure injected HFO polyurethane with a density of 42 kg/m³
- Temperature detection by means of a thermistor sensor (NTC probe)
- Operation control through a digital “touch” panel
- Automatic defrosting by hot gas
- Automatic evaporation of condensate water by means of a heat exchanger in copper
- Doors with automatic closing and a fixed opening position of 100°
- Hinges with automatic closing system
- Easily removable magnetic gaskets
- U-shaped guides and adjustable and extractable racks for grids
- Rounded internal corners for quick and easy cleaning
- Evaporator painted for cataphoresis with high corrosion resistance
- 7 GN 2/1 polyethylene grids as standard
- Height-adjustable stainless steel feet
- Lock with key and light placed under the control panel

OPTIONAL

- Stainless steel couple of “U” runners
- Stainless steel grid GN 2/1
- Polyethylene tray 600 x 400 mm
- Stainless steel grid 600 x 400 mm
- Couple “L” runners for grid 600 x 400 mm
- Kit 600 x 400 mm
- Led light
- Set of 5 castors

