



# IMMERSION CIRCULATOR SMARTVIDE 7

Max. capacity: 56 lt./14 gal.



- ✓ **Your appliance, always updated:** free firmware update, no matter where the appliance is.

## OPTIONAL

- Transport bag.
- Insulated tank.
- Lid for insulated tank.
- Floating balls.
- Janby Track (available through janby.kitchen).

## ACCESSORIES

- Needle probe for sous-vide cookers
- Probe foam seal
- Insulated tank for SmartVide immersion circulator
- Lid for SmartVide insulated tanks
- Floating balls for SmartVide
- SmartVide transport bag
- Smooth bags for sous-vide cooking
- Tank dividers

## SPECIFICATIONS

### Temperature

Display precision: 0.01 °C

Range: 5 °C - 95 °C

Permissible ambient temperature: 5 °C - 40 °C

### Time

Resolution: 1 '

Cycle duration: 1 ' - 99 h

### General features

Maximum recipient capacity: 56 l

Total loading: 2000 W

Submersible part dimensions: 117 mm x 110 mm x 147 mm

External dimensions (WxDxH): 124 mm x 140 mm x 360 mm

Net weight: 3.6 Kg

### Crated dimensions

440 x 190 x 310 mm

Gross weight: 5.5 Kg

## AVAILABLE MODELS

1180121 SmartVide 7 230/50-60/1 UK

1180123 SmartVide 7 120/60/1

1180120 SmartVide 7 230/50-60/1

1180124 SmartVide 7 208-240/50-60/1

\* Ask for special versions availability

## SALES DESCRIPTION

Commercial high-precision sous-vide cooker. Reliable, user-friendly, portable. Ideal for regeneration. Interchangeable between °C and °F.

- ✓ Bluetooth connectivity.
- ✓ HACCP-ready.
- ✓ Optional core probe.
- ✓ Firmware update.

## Portable precision cooker with stirrer for up to 56 lt. / 14 gal. containers. Designed for chefs, developed with chefs.

- ✓ The thick stainless steel, robust construction guarantees commercial performance. The front panel and the grip are made of fiber-glass-reinforced polyamide.
- ✓ SmartVide guarantees cooking at a **precisely controlled temperature** while preserving the quality of the product, enhancing flavor and texture. Equipped with a highly precise temperature control system to obtain extremely consistent results.
- ✓ Allows cooking food in their own juice and using this juice immediately after cooking to **enhance flavors**.
- ✓ Marinates and macerates an ingredient in **half the time**.
- ✓ **Infuses and flavors** oil, fat or other products applying the controlled temperature technique.
- ✓ Increases **profits** due to lack of product shrink.
- ✓ Requires **very little hands-on time**, allowing the Chef to do other tasks while the product is being cooked. Just program temperature and time, SmartVide will do the rest. 4 buttons and a full-color TFT display that offers **all the information at a glance** makes operation a child's play.
- ✓ SmartVide7 is **portable**: thanks to their ergonomic handle, SmartVide7 can be taken from a container to another easily. Additionally, the optional bag allows easy transport - wherever the Chef goes.
- ✓ **HACCP-ready**: thanks to Bluetooth connectivity, it is possible to export or print cooking results at the end of each cycle.



COMPONENT



# IMMERSION CIRCULATOR SMARTVIDE 7

Max. capacity: 56 lt./14 gal.



FOOD PRESERVATION AND SOUS-VIDE  
SOUS-VIDE COOKERS

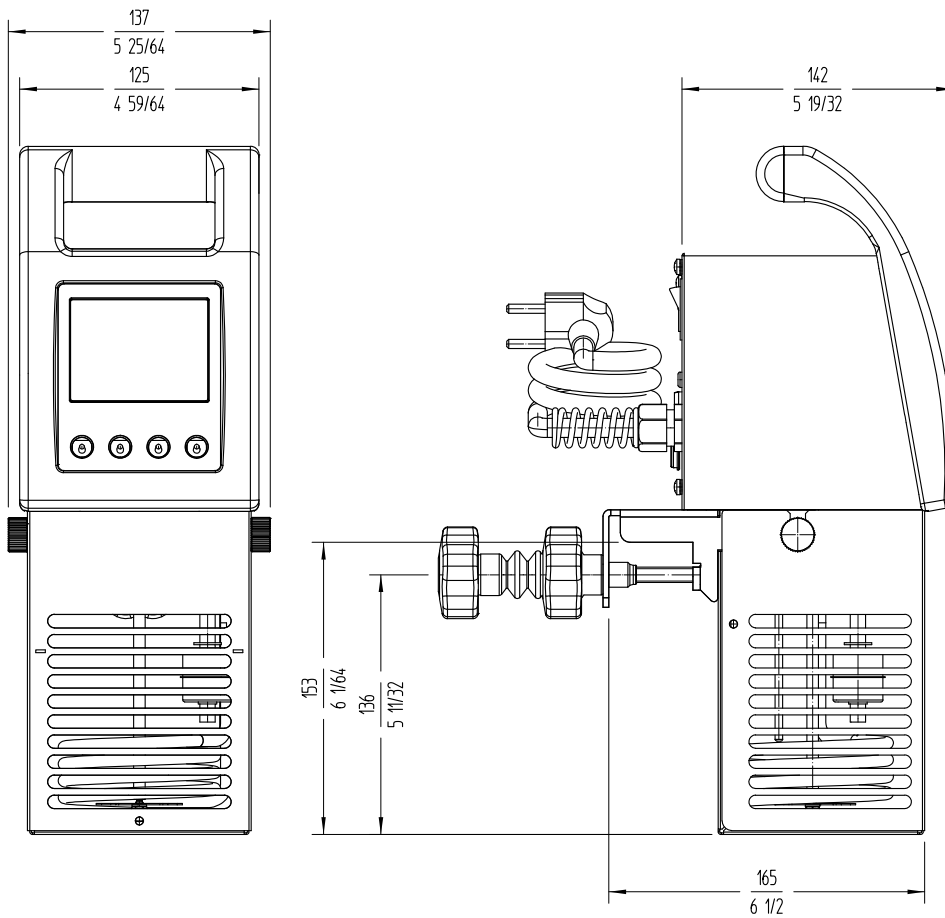

**sammic** | [www.sammic.com](http://www.sammic.com)  
Food Service Equipment Manufacturer

Polígono Basarte, 1. phone +34 943 15 72 36  
20720 Azkoitia, Spain [sales@sammic.com](mailto:sales@sammic.com)



Project	Date
Item	Qty
Approved	

product sheet  
updated 19/04/2023