



COMBI CK-241

2-in-1. Compact vegetable slicer + cutter. 1 speed.



DYNAMIC PREPARATION
FOOD PROCESSOR / VEG PREP COMBI MACHINES



SALES DESCRIPTION

Compact ACTIVE line. 1-speed motor block + vegetable slicer attachment + 4.4 l cutter bowl.

Vegetable slicer function: a perfect cut.

- ✓ High precision settings and comprehensive cutter and disc design aimed at obtaining a perfect cut.
- ✓ Gravity product expulsion ramp allow to reconstruct the sliced product for storing or presentation purpose. (Watch video)
- ✓ Ejection disc included for the products that require its use.
- ✓ It can be fitted with a wide range of discs and grids of the highest cutting quality.
- ✓ Combining these accessories together to obtain more than 35 different types of cuts and grating grades.

Cutter function: efficiency and performance.

- ✓ Possibility of programming by time and pulse button.
- ✓ 4.4 l-bowl equipped with lateral stirrer and high shaft to obtain a bigger production.
- ✓ Transparent polycarbonate lid equipped with hole to add ingredients in use.
- ✓ Lid complete with gasket to avoid product overflowing.
- ✓ Homogeneous and fine mixing result thanks to the lateral stirrers and invert-blade technology.
- ✓ The lateral stirrers avoid product overheating.
- ✓ Very uniform finish due to the movement generated the special position of the cutting edges.
- ✓ Depending on the purpose, the possibility of using optional smooth or perforated blades.

Built to last

- ✓ Sturdy construction in food-grade best quality materials.
- ✓ High power asynchronous motor.

Maximum comfort for the user

- ✓ Ergonomic design: product sliced in one single movement.
- ✓ Cutter bowl equipped with ergonomic handle.
- ✓ Lateral product output: requires less space on the worktop and guides the product, avoiding splashes.
- ✓ Adjustable product ejection direction to adapt to the workflow in the preparation area.
- ✓ Recessed cored relief allows for any position in the kitchen, side walls, back wall, light and compact, this machine can fit.
- ✓ The electronic command panel is very intuitive.

Maintenance, safety, hygiene

- ✓ Lever, lid and bowl are easily removable for cleaning purposes.
- ✓ Stainless steel, dishwasher-safe discs. The removable blades allow for an even more thorough and efficient cleaning.
- ✓ Combination of safety systems: head, cover, bowl, power switch.
- ✓ Complete error warning system.
- ✓ Appliance certified by NSF International (regulations on hygiene, cleaning and materials suitable for contact with foods).
- ✓ 100% tested.

INCLUDES

- ✓ 1-speed motor block.
- ✓ Vegetable slicer attachment.
- ✓ Cutter bowl with toothed blades.
- ✓ Gravity product expulsion ramp.
- ✓ Ejection disc.

OPTIONAL

- Hub with smooth blades.
- Hub with perforated blades.

ACCESSORIES

- FCS slicing discs
- FCOS rippled slicing disc
- FMS dicing grid
- FFS chipping grid
- FCES julienne discs
- SHS shredding & grating discs
- Disc and grid packs

SPECIFICATIONS

Total loading: 800 W

As vegetable preparation machine

Hourly production: 50 kg - 350 kg
 Inlet opening: 89 cm²
 Disc diameter: 180 mm
 Speed as veg. slicer: - 1500 rpm
 External dimensions (W x D x H): 378 mm x 309 mm x 533 mm
 Net weight (Veg.Pre.): 15.2 kg

As cutter

Bowl capacity: 4.4 l
 Speeds as cutter (positions): - 1500 rpm
 External dimensions (W x D x H): 252 mm x 309 mm x 434 mm
 Net weight (Cutter): 14.2 kg
 Noise level (1m.): <70 dB(A)
 Background noise: 32 dB(A)

Crated dimensions

[n:embalaje_ancha] x [n:embalaje_fondo] x [n:embalaje_alto] [m:embalaje_ancha]
 Volume Packed: 0.1 m³
 Gross weight: 20.7 kg



product sheet
updated 05/12/2023



COMBI CK-241

2-in-1. Compact vegetable slicer + cutter. 1 speed.



AVAILABLE MODELS

1050900	Combi vegetable prep.-cutter CK-241 230/50/1
1050902	Combi vegetable prep.-cutter CK-241 230/50/1 UK
1050906	Combi vegetable prep.-cutter CK-241 220/60/1
1050912	Combi vegetable prep.-cutter CK-241 120/60/1
1050914	Combi vegetable prep.-cutter CK-241 2D 120/60/1 · 2 discs included

* Ask for special versions availability

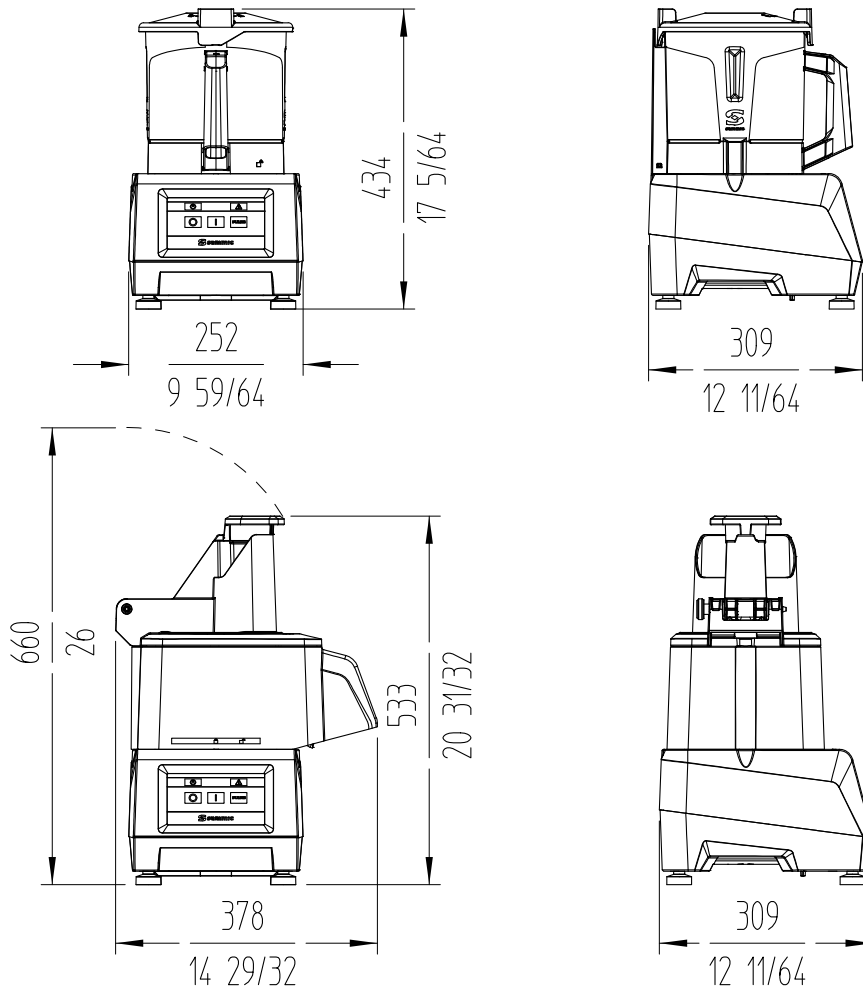

DYNAMIC PREPARATION
FOOD PROCESSOR / VEG PREP COMBI MACHINES

sammic | www.sammic.com
Food Service Equipment Manufacturer

Polígono Basarte, 1. phone +34 943 15 72 36
 20720 Azkoitia, Spain sales@sammic.com



Project	Date
Item	Qty
Approved	

product sheet
updated 05/12/2023