



VEGETABLE PREPARATION MACHINE CA-31

Vegetable preparation machine. Production up to 450 kg.



DYNAMIC PREPARATION
COMMERCIAL VEGETABLE PREPARATION MACHINES

SALES DESCRIPTION

Single-speed motor block + regular hopper.

A perfect cut

- ✓ High precision adjustments to obtain a uniform and excellent-quality cut.
- ✓ It can be fitted with a wide range of discs and grids of the highest cutting quality. Combining these accessories together to obtain more than 70 different types of cuts and grating grades.

Built to last

- ✓ Made from stainless steel and food-grade materials of the highest quality: stainless steel motor block and food-grade aluminium head.
- ✓ High power asynchronous motor.

Maximum comfort for the user

- ✓ Ergonomic design: product sliced in one single movement.
- ✓ Lateral product output: requires less space on the worktop and guides the product, avoiding splashes.
- ✓ The electronic command panel is very intuitive.

Maintenance, safety, hygiene

- ✓ Lever and lid easily removable for cleaning purposes.
- ✓ Combination of safety systems: head, cover, power switch.
- ✓ Appliance certified by NSF International (regulations on hygiene, cleaning and materials suitable for contact with foods).
- ✓ 100% tested.

INCLUDES

- ✓ Single-speed motor block.
- ✓ Regular hopper.

OPTIONAL

- Tube head for long products.
- Discs and grids.
- Support-trolley.
- Grid cleaning kit.

ACCESSORIES

- FCC curved slicing discs
- FCO rippled slicing discs
- FFC chipping grids
- FMC dicing grids
- FCE julienne discs
- FR shredding & grating discs
- Long vegetable attachment
- Disc and grid packs
- Disc and grid holder
- Stand-trolley
- Grid cleaning kit
- FC-D slicing discs
- SH shredding & grating discs

SPECIFICATIONS

Hourly production: 150 kg - 450 kg

Inlet opening: 136 cm²

Disc diameter: 205 mm

Motor speed: 365 rpm

Loading

Single Phase: 550 W

Three phase: 550 W

Electrical connection: --

Noise level (1m.): <70 dB(A)

Background noise: 32 dB(A)

External dimensions (WxDxH)

Width: 389 mm

Depth: 405 mm

Height: 544 mm

Net weight: 21 kg

Crated dimensions

435 x 430 x 600 mm

Volume Packed: 0.11 m³

AVAILABLE MODELS

1050701 Vegetable preparation machine CA-31 230-400/50/3N

1050700 Vegetable preparation machine CA-31 230/50/1

1050702 Vegetable preparation machine CA-31 120/60/1

1050705 Vegetable preparation machine CA-31 220/60/1

1050707 Vegetable preparation machine CA-31 220-380/60/3N

1050712 Vegetable preparation machine CA-31 230/50/1 UK

* Ask for special versions availability





VEGETABLE PREPARATION MACHINE CA-31

Vegetable preparation machine. Production up to 450 kg.



DYNAMIC PREPARATION
COMMERCIAL VEGETABLE PREPARATION MACHINES

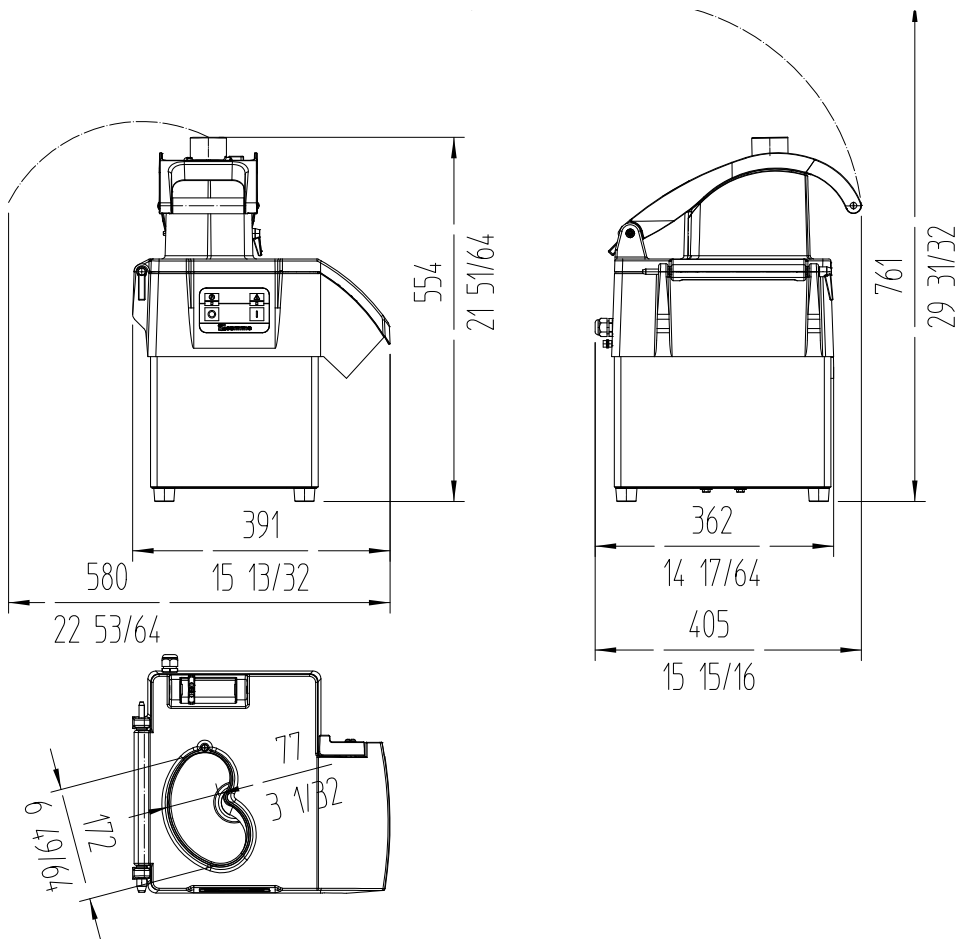

 **sammic** | www.sammic.com
Food Service Equipment Manufacturer

Polígono Basarte, 1. phone +34 943 15 72 36
20720 Azkoitia, Spain sales@sammic.com



Project	Date
Item	Qty
Approved	

product sheet
updated 20/11/2023